

recurrent fragments /

OUR GROUP DECIDED TO CREATE ONE MODULAR OBJECT THAT COULD BE USED IN DIFFERENT MANNERS DEPENDING ON THE SITUATION. THE STRUCTURE IS MADE ENTIRELY OUT OF WOOD, AND CAN BE MODIFIED IN ORDER TO PROVIDE SHADE TO PEDESTRIANS OR TO BE TRANSFORMED INTO CABINS IN ORDER TO BE USED IN MARKETS AND FAIRS THAT

TAKE PLACE ON THE PARK. WE EXPLORED WOOD AS A MATERIAL AND ALL ITS POSSIBLE CONFIGURATIONS SO THAT WE COULD TAKE ADVANTAGE OF ITS BENEFITS IN ORDER TO MAKE JOINTS THAT WOULD BE RESISTANT, STEADY AND AESTHETICALLY PLEASANT.

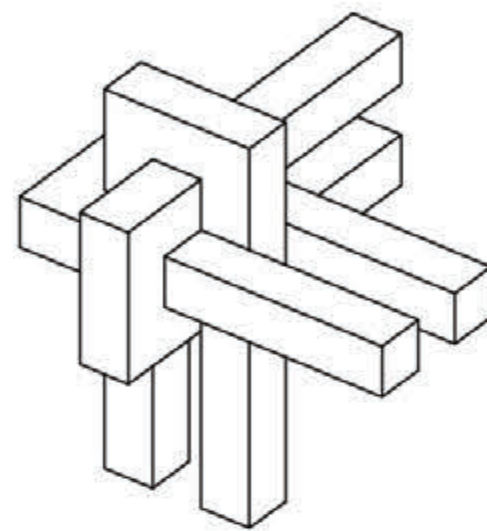
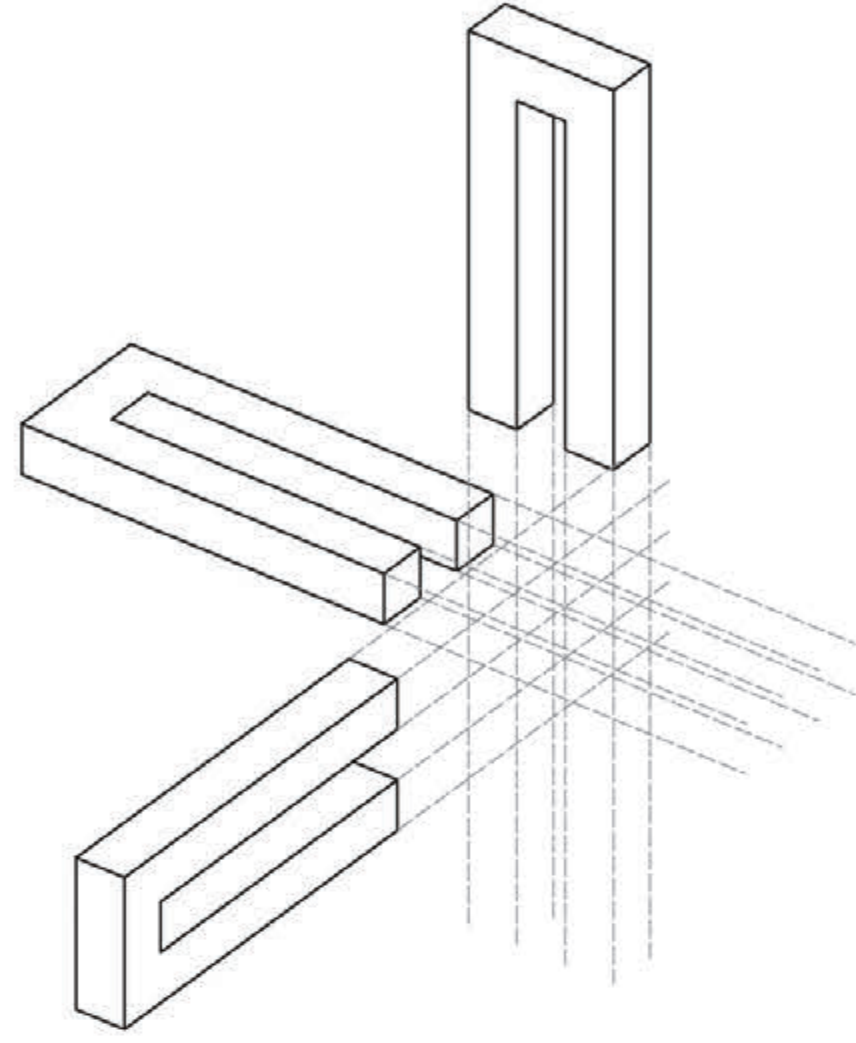
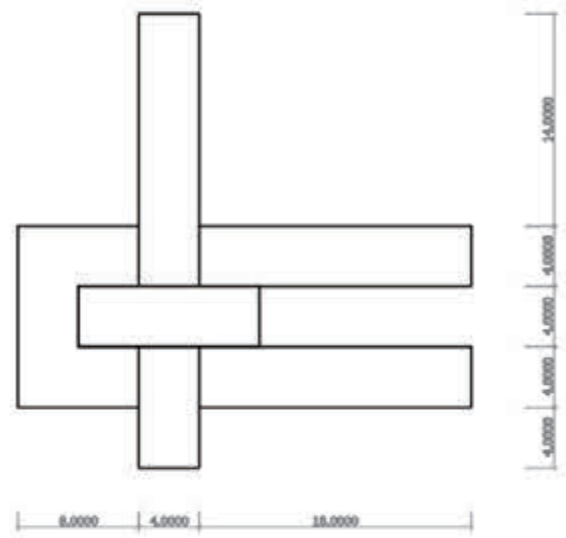
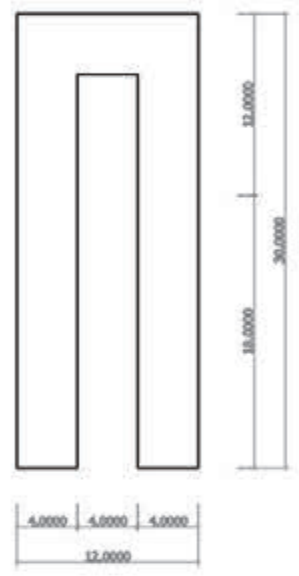
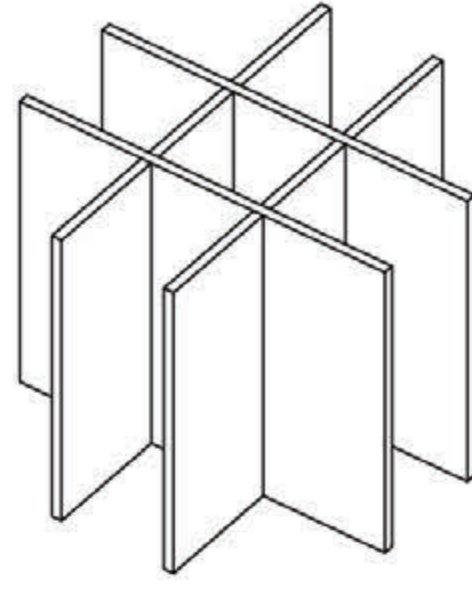
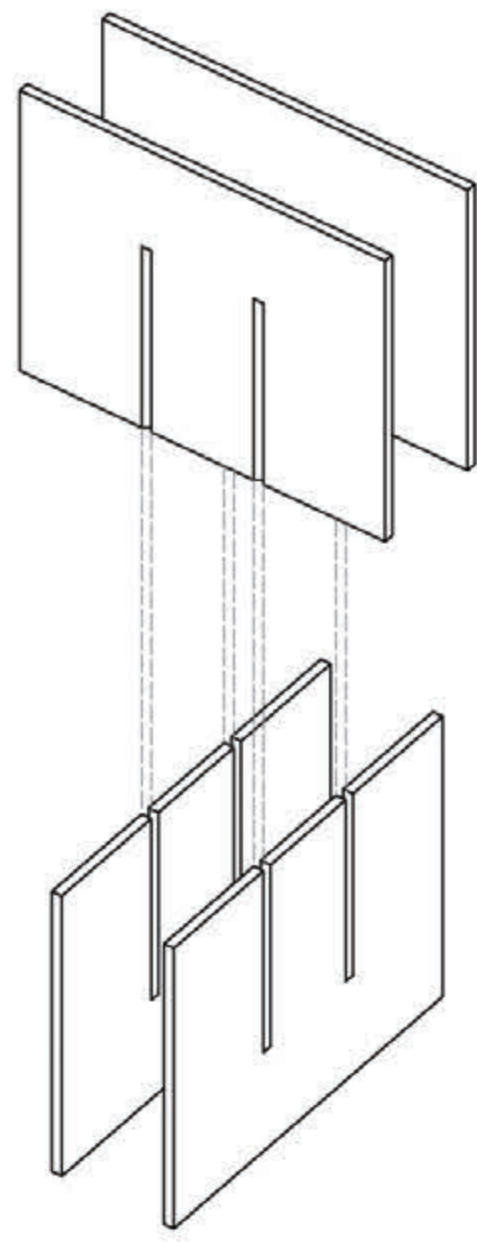
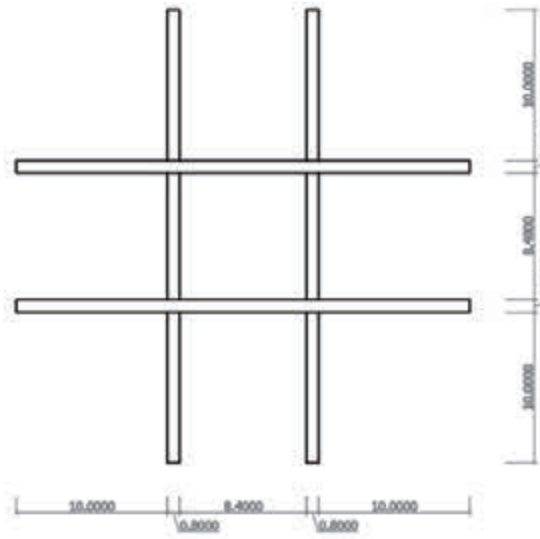
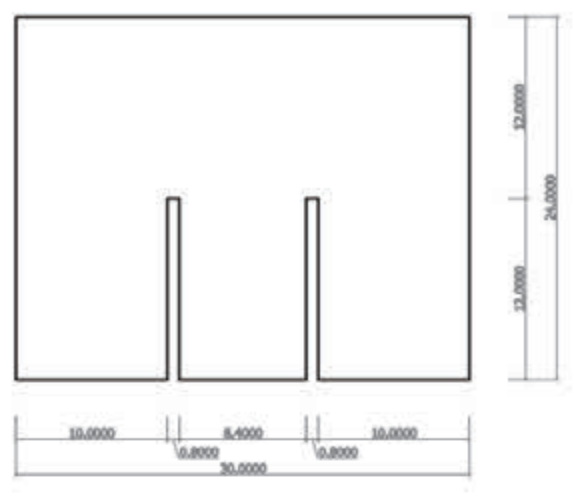

FABRICATION METHOD
SCALE 1:5 AT B1

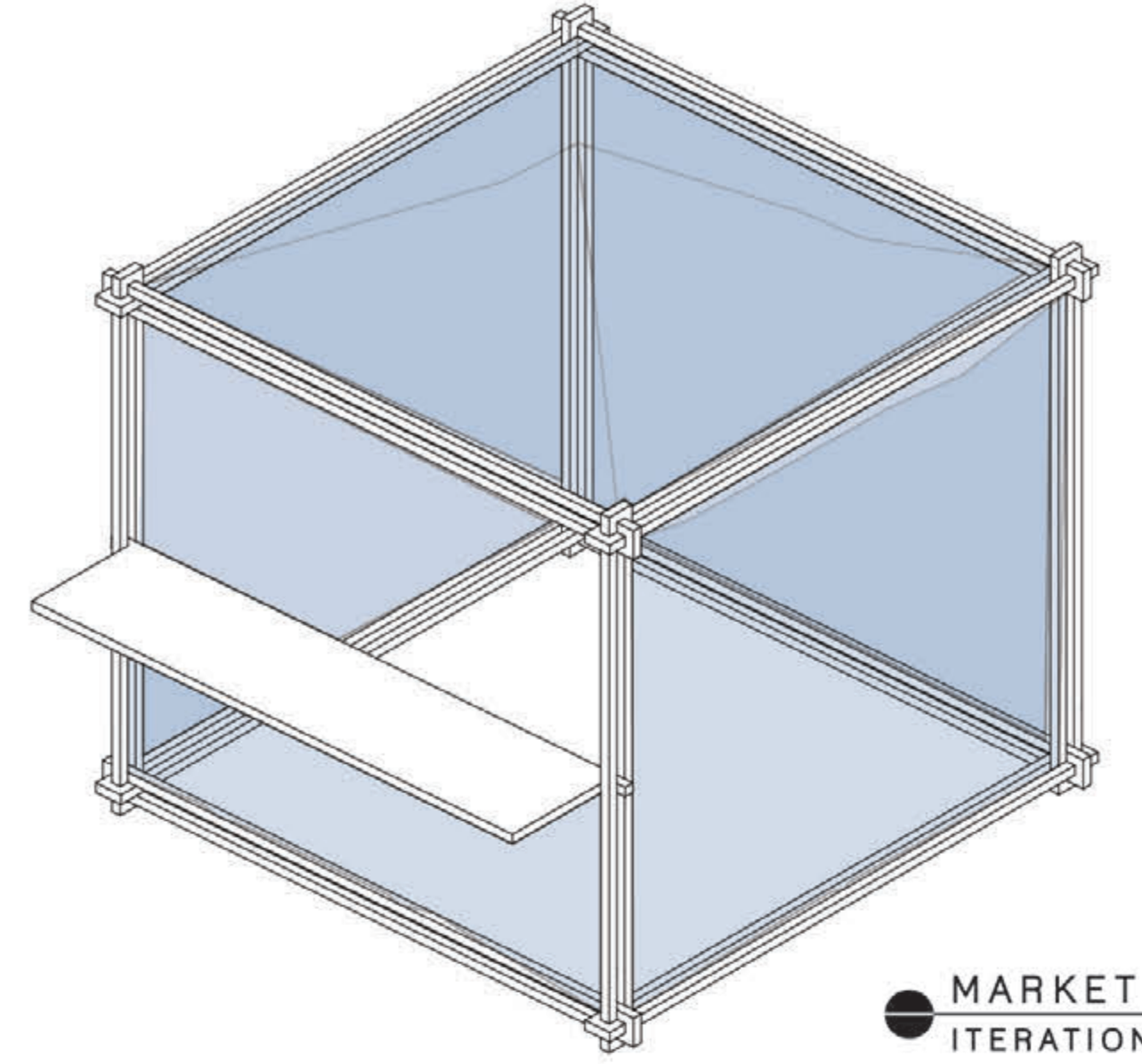

MARKET STALL
ITERATION 01

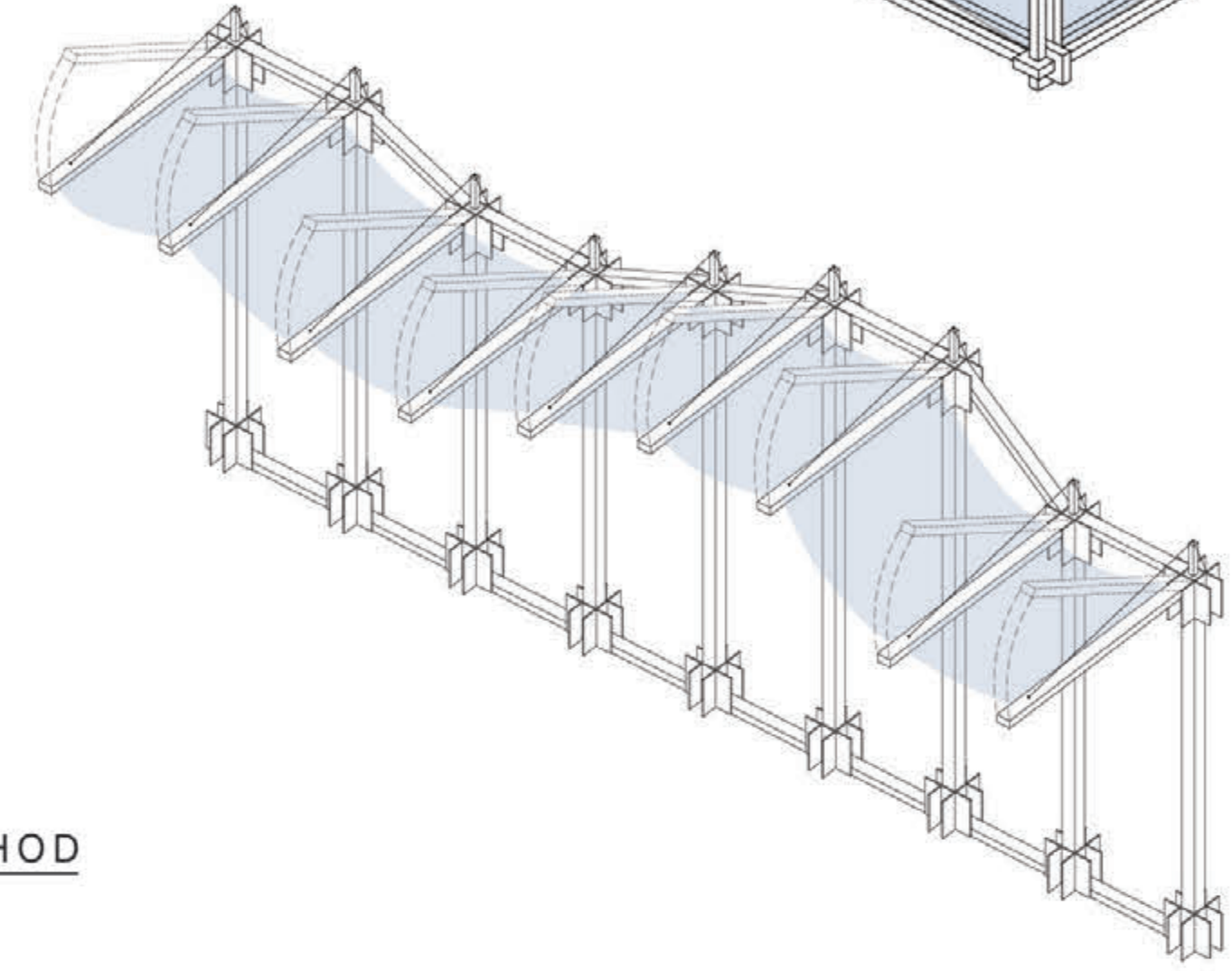

SHADING DEVICE
ITERATION 02

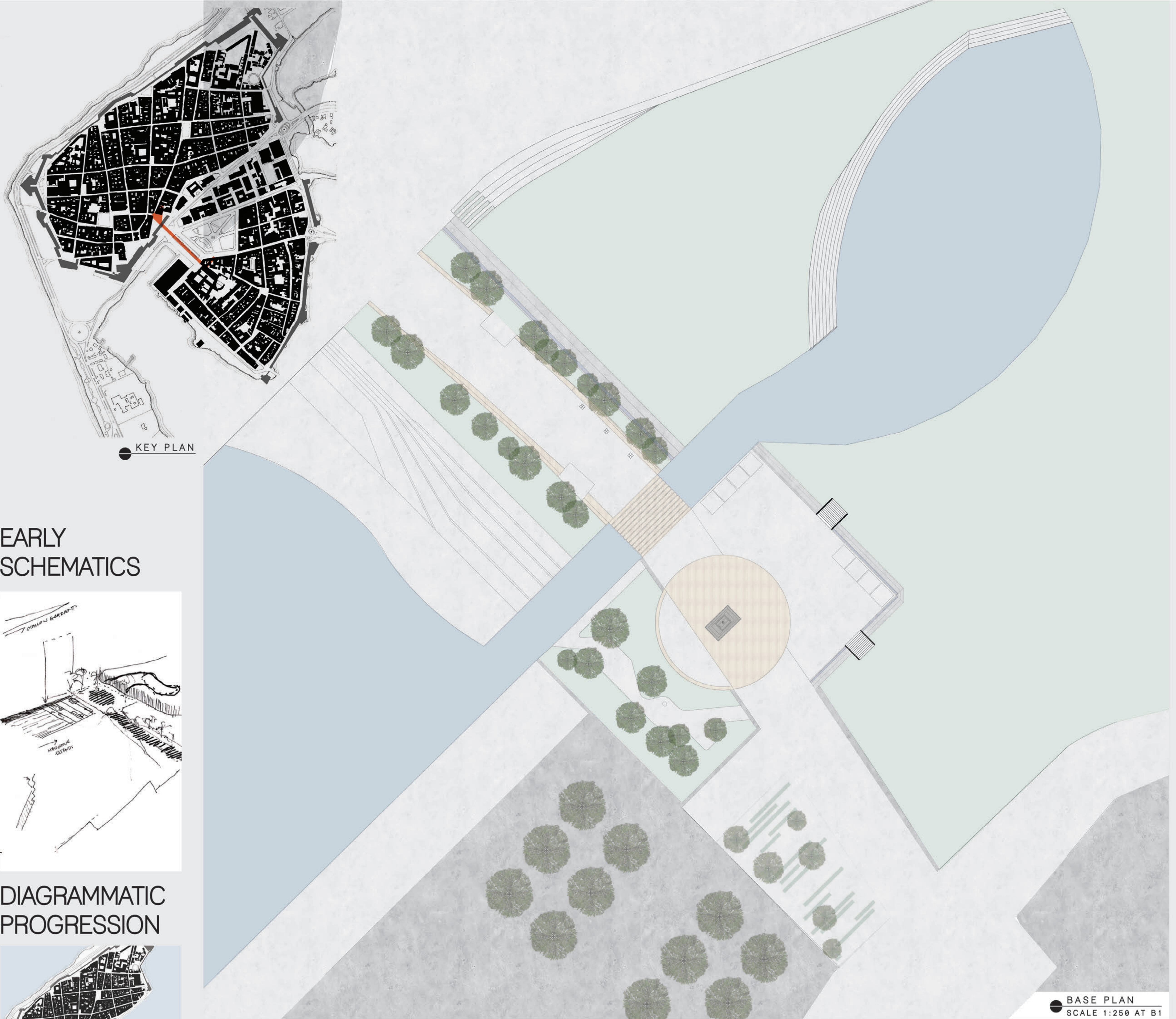

KEY PLAN

EARLY SCHEMATICS

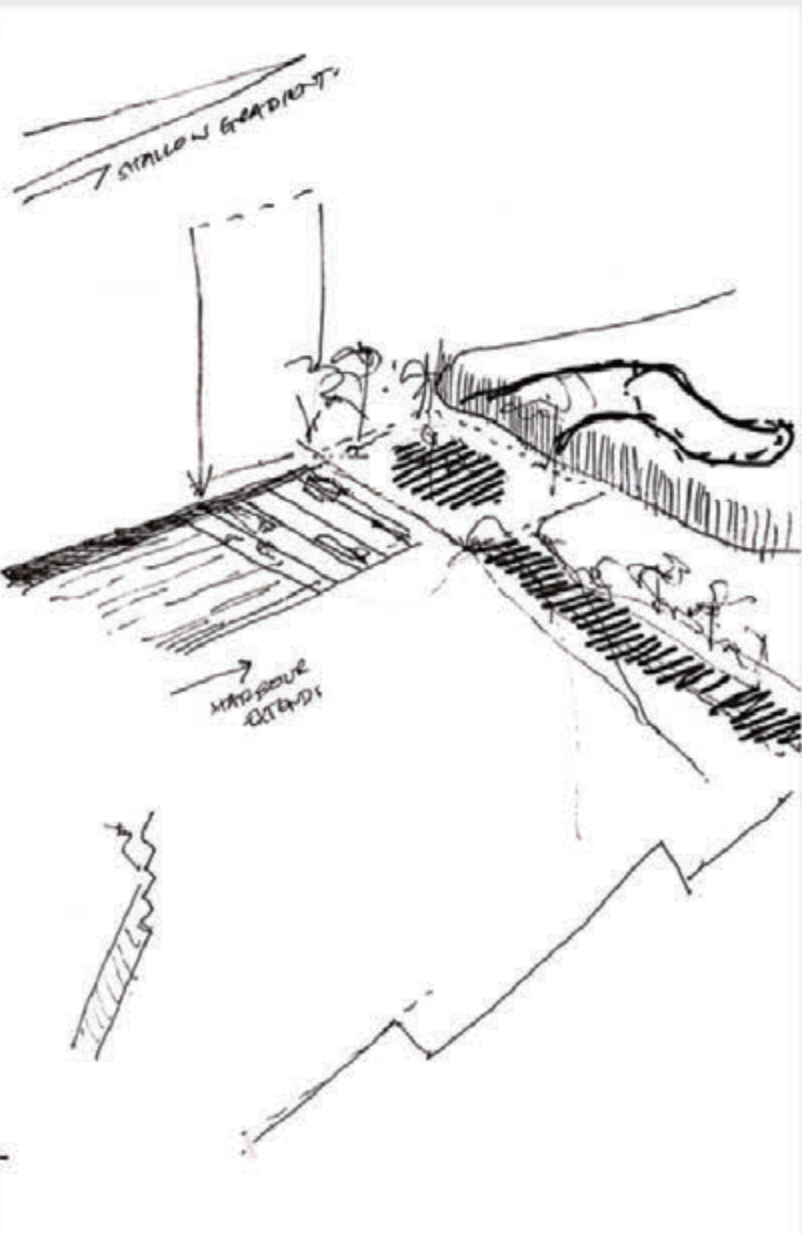

DIAGRAMMATIC PROGRESSION



BASE PLAN
SCALE 1:250 AT B1

working with the void

A PLAZA REVITALIZED AND RECONNECTED

OUR PROPOSAL FOR ARTEFACT WEEK SPRINGBOARDS OFF THE PREVIOUS TOPIC OF FOCUS FOR THE DERIVA AND INTERVENTION: BRINGING A NEW AWARENESS AND CONNECTION TO WATER TO CARTAGENA'S INHABITANTS WHERE THERE PREVIOUSLY WAS NONE.

ALLOTTED A SITE THAT RUNS THROUGH THE BUSY PUBLIC SQUARES OF PLAZA DE LOS COCHES AND PLAZA DE LA PAZ, THE OBJECTIVE OF OUR URBAN SCHEME BECAME TO IMPLEMENT A PHYSICAL AND SYMBOLIC PRESENCE OF WATER AT THE SITE. WE DID THIS THROUGH A SERIES OF CONSIDERED VOIDS.

OUR PROCESS INVOLVED EXAMINING TRANSFORMATIONS THAT HISTORY HAD BROUGHT TO THIS SITE (PREVIOUSLY THE STRAIT BETWEEN TWO ISLANDS). THE RESULTING SCHEME INVOLVES STRIPS OF FUNCTIONAL, ACTIVATED PUBLIC SPACE.

WEEK 02 /
ARTIFACT WEEK /
SECTION 13 /
GRUPO 04 /

ALVARO F FRANCO VARGAS /
RENEE JACOVIDES /
LUCA SECCI /
MARINA COCCARO /

31ST INTERNATIONAL
WORKSHOP /
CARTAGENA, 2017 /
201718_ARQU3808 /

MATERIAL CONSIDERATIONS

LIGHTER TONES OF STONE AND CONCRETE ARE SELECTED FOR MAXIMUM THERMAL COMFORT. PALETTE IS MIXED WITH TACTILE TIMBERS AND A RICH PROVISION OF NATURAL FINISHES.

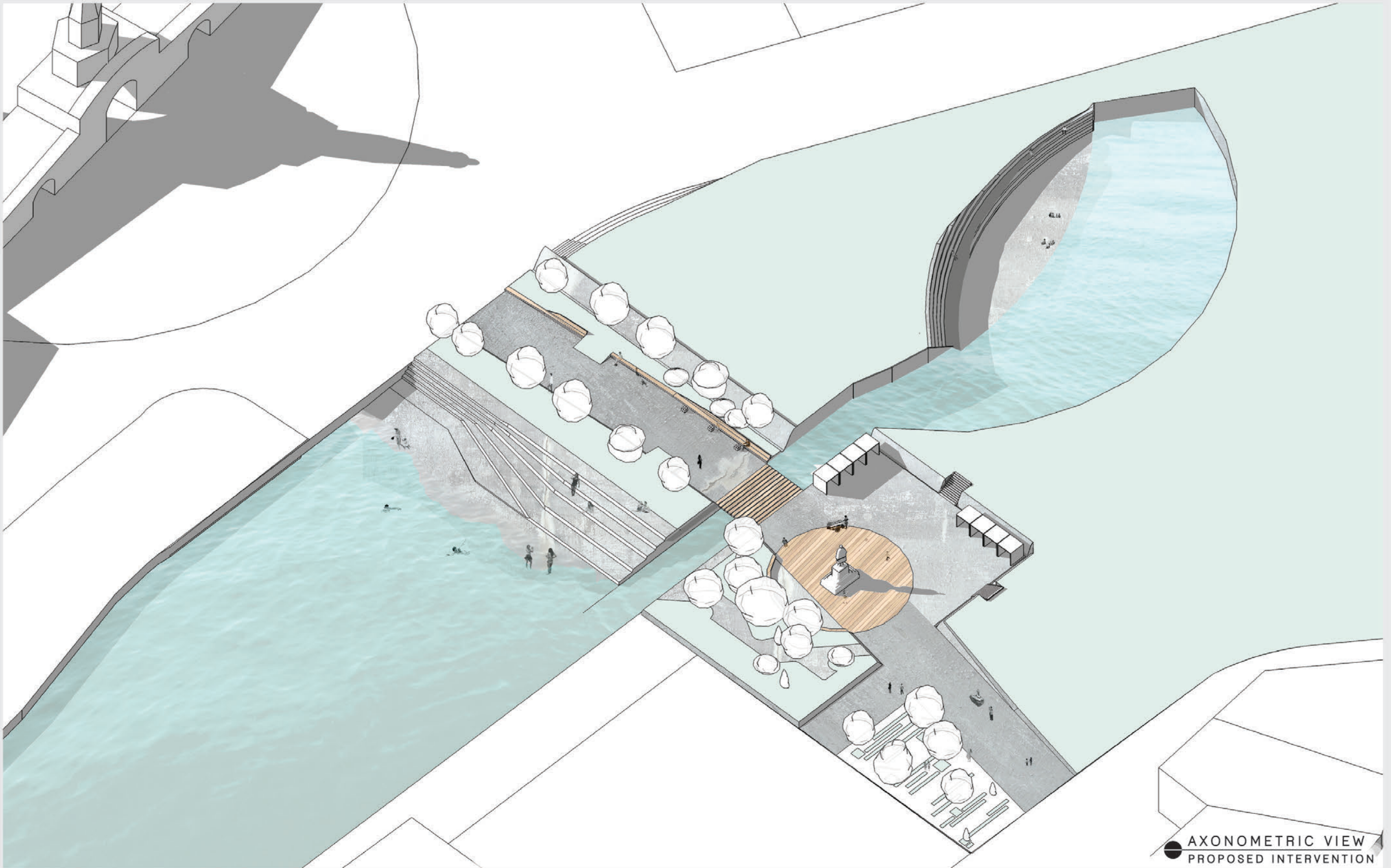
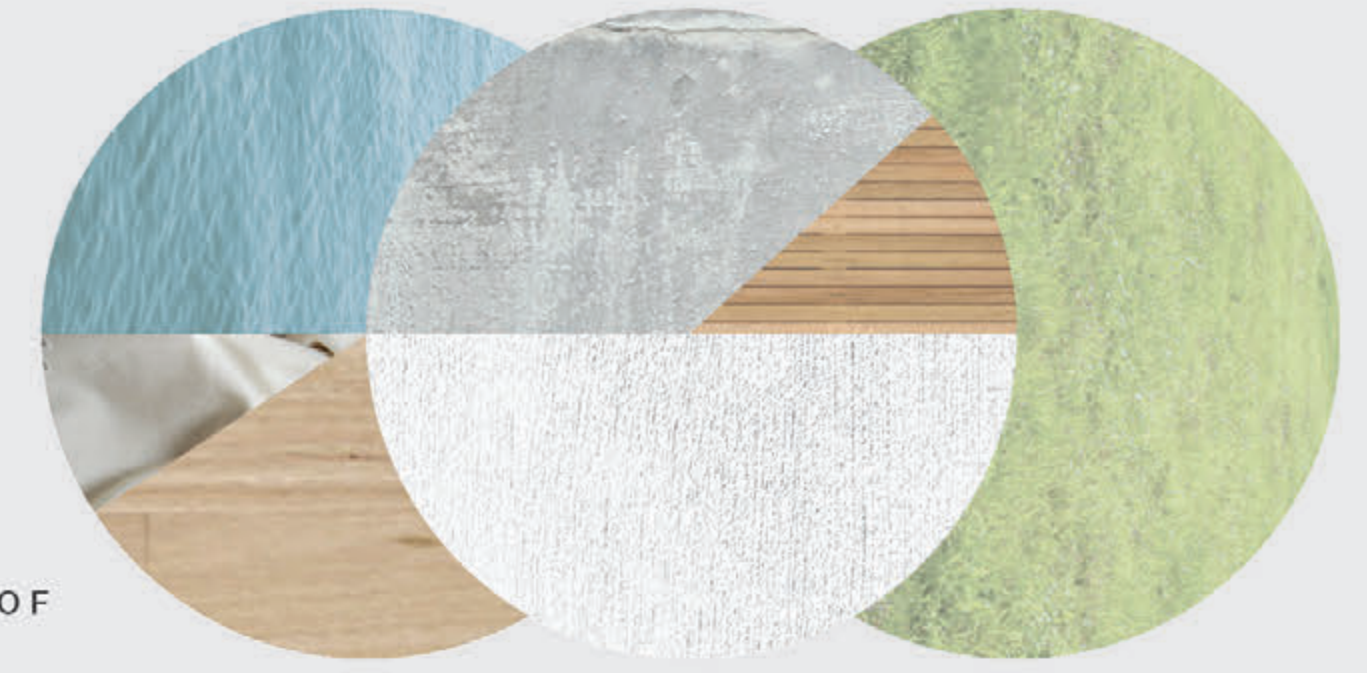

AXONOMETRIC VIEW
PROPOSED INTERVENTION

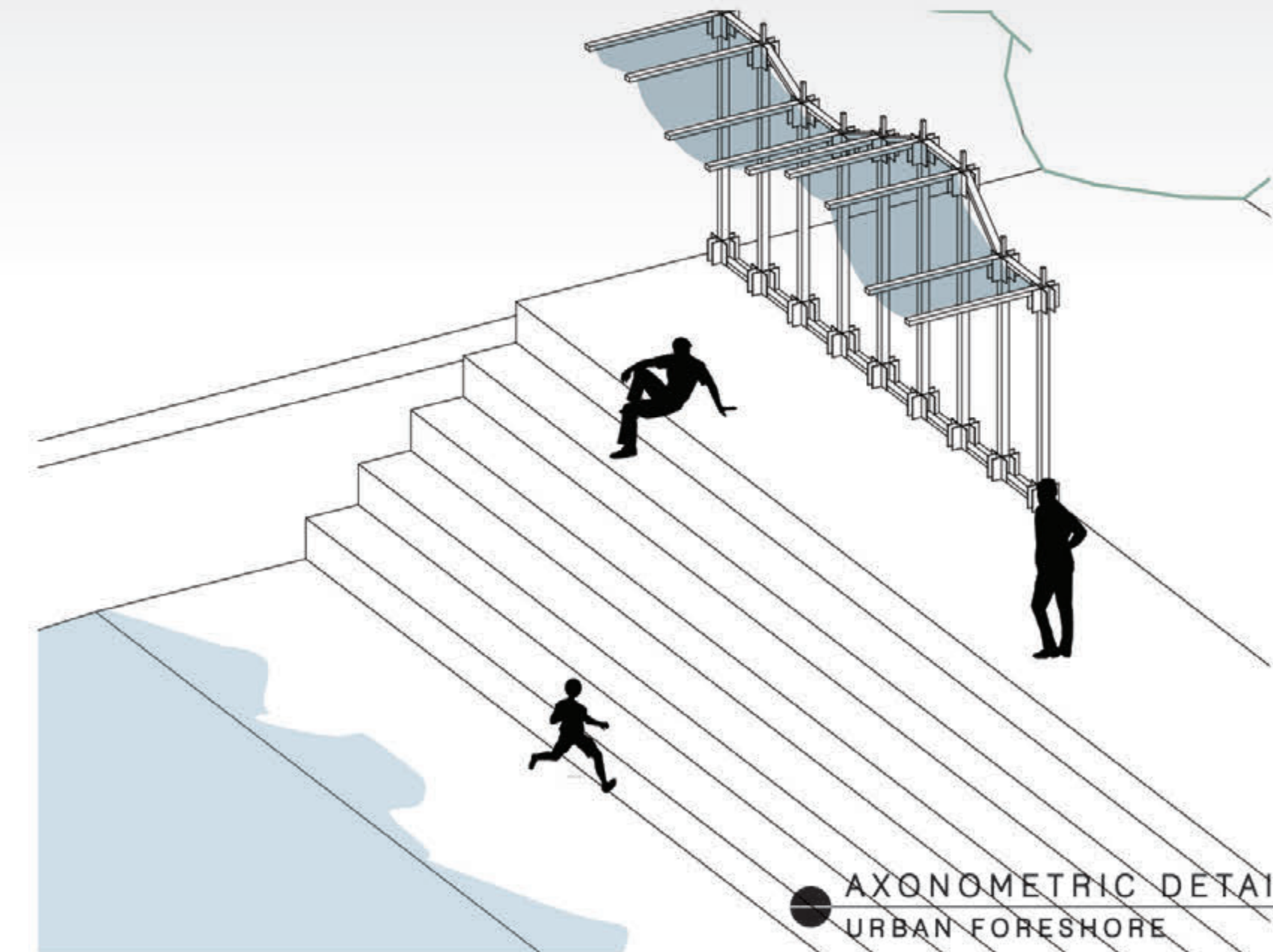

AXONOMETRIC DETAIL
URBAN FORESHORE

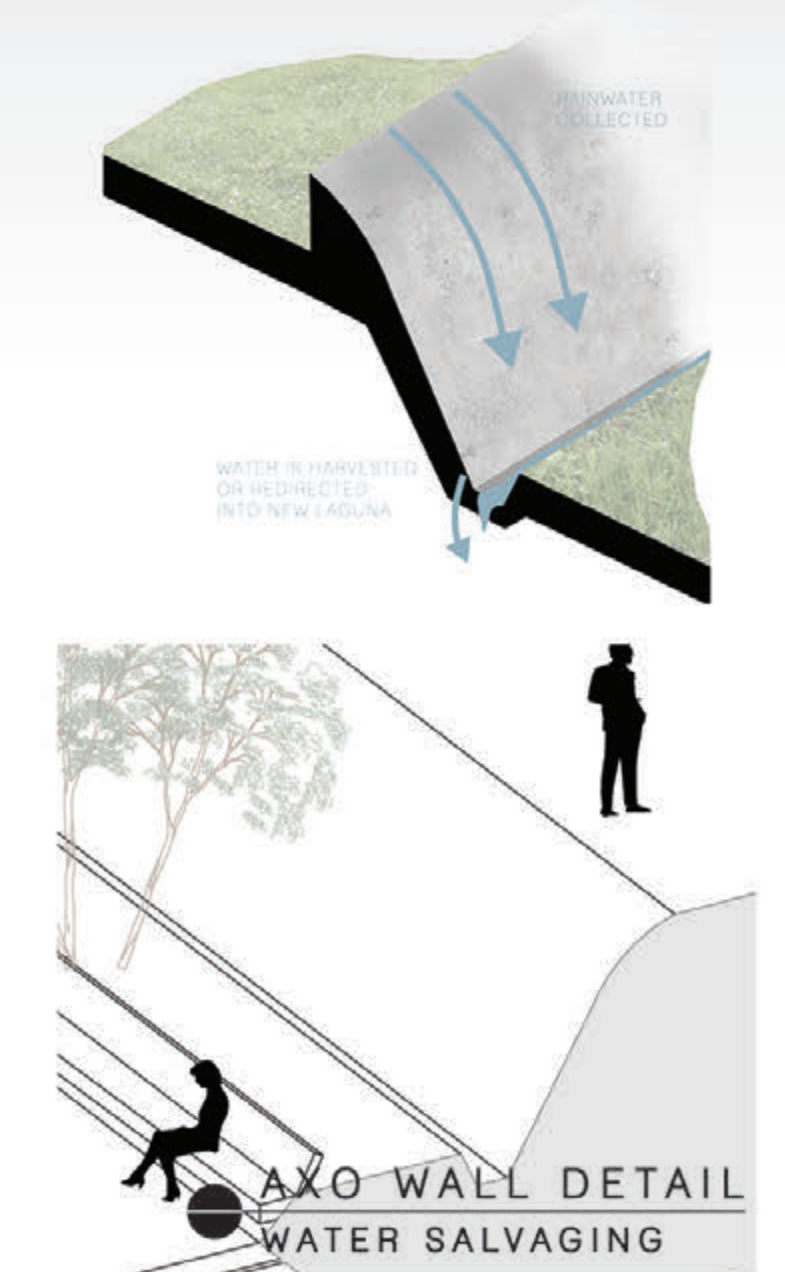

AXO WALL DETAIL
WATER SALVAGING

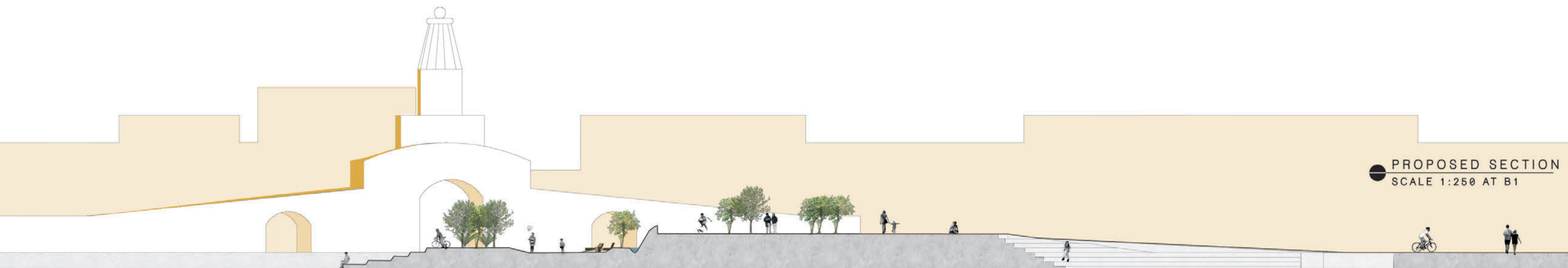

PROPOSED SECTION
SCALE 1:250 AT B1